

CHLORTAINER®

Total Containment System

For Chlorine Processing

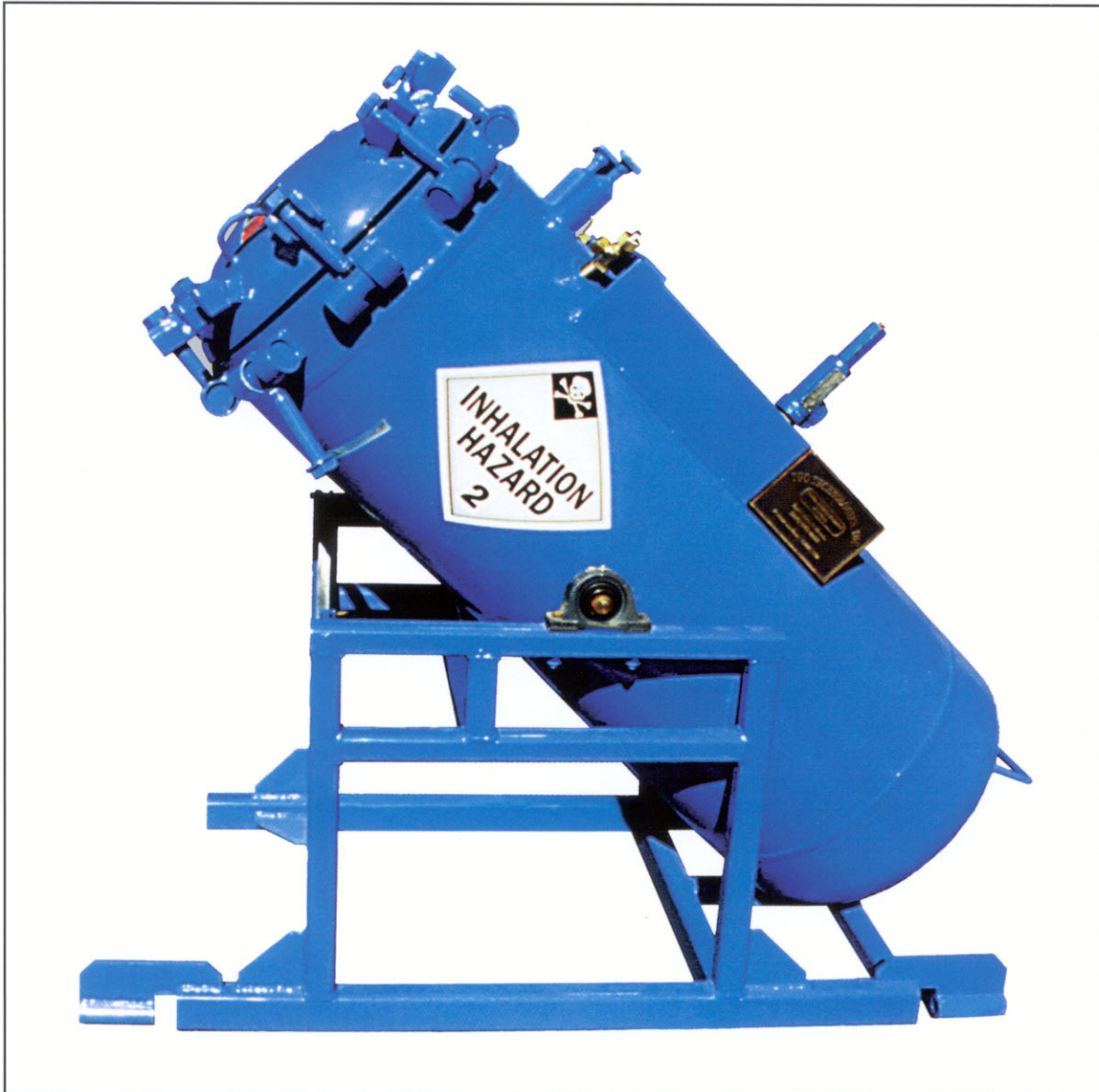

Available for Single or Dual 150-Pound Cylinders

- Safest and Most Dependable Leak Prevention Available
- 'Zero' Release Technology Provides Passive Mitigation
- Complies with Article 80 of the Uniform Fire Code

The 150-pound cylinders are loaded into the ChlorTainer vessel and sealed for processing.

Should the contained cylinder fail, the system continues to process the gas at a normal rate, as the vessels are designed to withstand the maximum anticipated pressure of a release.

The passive technology safeguards the operators and the environment against an accidental release.

No waste is generated and a scrubber is not required.

Includes SCADA compatible weighing system with 12 inch dial.

Design Pressure	285 psig @ 300°F
Minimum Design Metal Temperature	-20°F @ 285 psig
Corrosion Allowance	1/16 inch
Fabrication Code	ASME Section VIII, Div 1
Hydro test	380 psig per UG-99
Interior Paint	2.5-3.0 Mils DFT Inorganic Zinc
Exterior Paint	4-6 Mils DFT Epoxy 2 Mils DFT Polyurethane
Welding	ASME Code Section IX
Vessel Weight	1,500 pounds
Materials Used	Carbon Steel Vessel, Monel 400 Bosses
NOTE: Materials used may vary when designed for other toxic gases.	

TGO Technologies, Inc
 3450-C Regional Parkway
 Santa Rosa, CA 95403
 707-576-7778
 www.tgotech.com
 sales@tgotech.com

800-543-6603

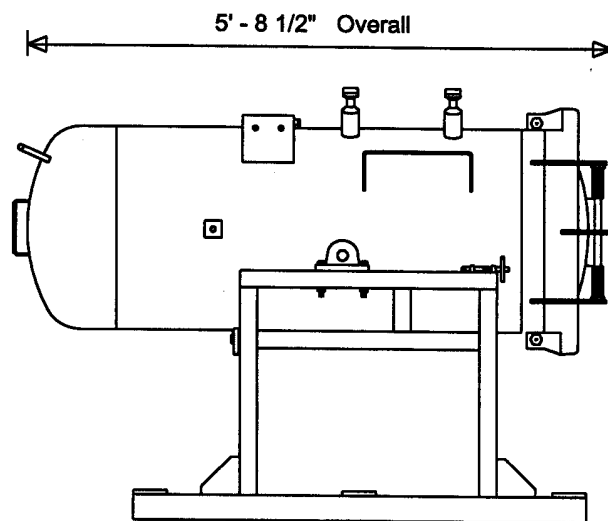

SIDE VIEW OF VESSEL
 Positioned for cylinder loading

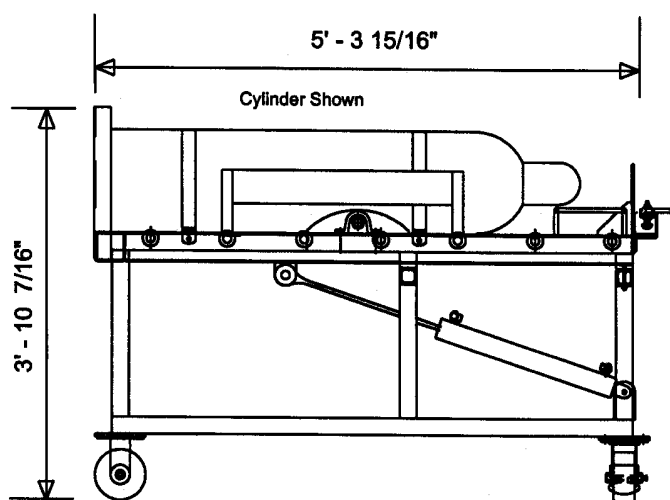

SIDE VIEW OF LOADER
 Positioned for cylinder loading

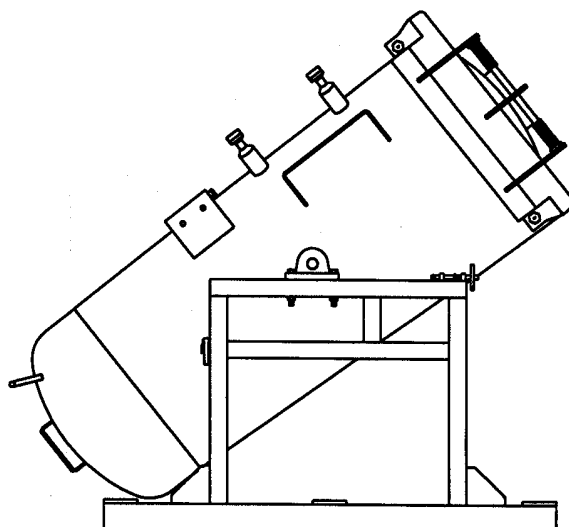

SIDE VIEW OF VESSEL
 Positioned for operating